

Potting Bench

We hope that you enjoy this free woodworking project provided to you as a special thanks for being a member of Lowe's Woodworkers.



Every member of the family will find this potting bench to be a handy addition. Pigeonholes and pegs organize small tools, while a sturdy shelf below holds weightier items.

Instructions

General: Assemble using either nails or exterior screws, [predrilling](#) and [counter-sinking](#). Glue joints first, removing excess glue with a damp cloth. Patch all holes with wood putty, and sand. See Figure 5 for measurements.

Step 1: Cut all materials according to the Cut List, except for the top edge band.

Step 2: Assemble frame (see Figure 1).

a. Mark the front and back legs at 13 inches; also mark the back legs at 35 $\frac{1}{4}$ inches.

b. Align the top edge of the corner anchors to the marks, and attach using 1 $\frac{1}{4}$ -inch screws.

c. Attach two 16-inch side shelf supports to a front and back leg, top and bottom.

d. Attach the four 48-inch top and bottom front and back supports to the completed end.

LOWE'S LIST

Lumber

- 2 (8-foot-long) 1 x 2s
- 1 (6-foot-long) 1 x 4
- 2 (8-foot-long) 1 x 6s
- 4 (10-foot-long) 1 x 6s
- 6 (8-foot-long) 2 x 2s
- 1 (4- x 8-foot) lattice panel
- 7 (3 $\frac{1}{2}$ -inch x $\frac{1}{2}$ -inch) wooden shaker pegs

Hardware/ Finishing Materials

- 8 (2x2) Simpson corner anchors
- 1 box (1 $\frac{1}{4}$ -inch) Simpson screws
- 1 box (#8 x 2-inch) exterior wood screws
- 24 (3 $\frac{1}{4}$ -inch) exterior or brass wood screws
- 1 box 4d galvanized finishing nails
- 1 box 8d hot-dipped galvanized finishing nails
- exterior wood glue
- adhesive caulking
- paint or stain

*Availability varies by market.

e. Attach the remaining two front and back legs to the four 48-inch front and back shelf supports in the same manner.

f. Attach the other two top and bottom 16-inch side supports to complete the frame.

g. Mark the center of each of the 48-inch front and back supports, and predrill holes using a $\frac{1}{8}$ -inch bit. Position the two center supports, and secure to the frame using 8d hot-dipped galvanized finishing nails.

Step 3: Add the bottom shelf (see Figure 2).

a. Notch the first board for the front and back legs.

b. Using a $\frac{1}{8}$ -inch bit, predrill four holes in the first board, each about $\frac{3}{4}$ inch in from each end. This should place the screws in the center of the shelf support. Attach using four 2-inch screws per board.

c. Attach the next seven boards, predrilling each corner $\frac{3}{4}$ inch in from the ends, and then securing the board with 2-inch screws to the shelf supports. Keep boards snug to one another and flush with the front and back edges of the supports.

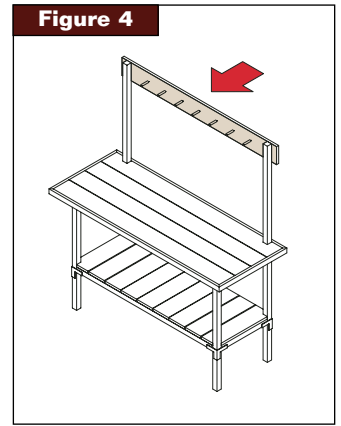
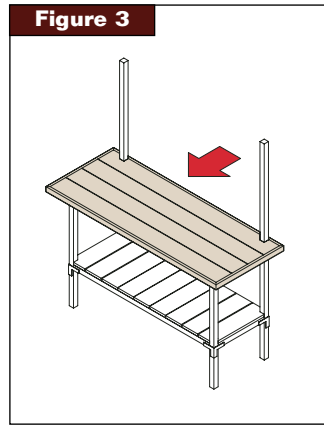
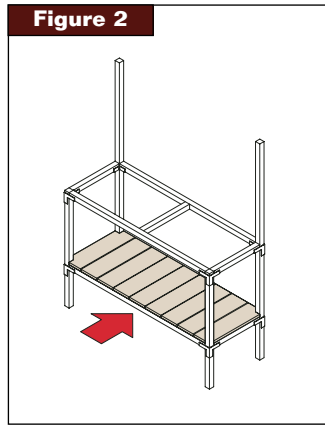
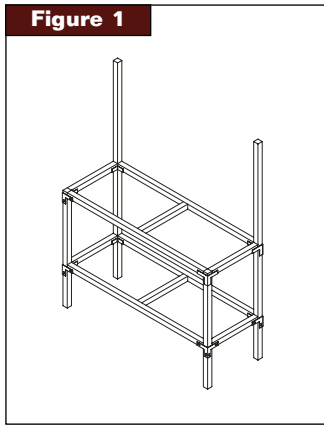

d. Repeat Steps 3a and 3b for notching and attaching the last bottom shelf board.

Step 4: Attach the top shelf boards. (Note: Top shelf boards will be centered on the frame. See Figure 3.)

a. Cut a 2¼- x 1½-inch notch in the back shelf board where it will meet the back legs when centered. This will leave ¾ inch of back overhang to carry the backsplash. Pre-drill, then secure the board to the frame with 2-inch screws, which should be driven into the center of the supports.

b. Attach the next two boards in the same fashion (without notching), aligning with the back board.

c. Attach the final shelf board; note that it will overhang the front of the frame by about 3 inches. Pre-drill, then secure to side supports and front support with 2-inch screws every 6 inches.

d. Mark the center support, and pre-drill the shelf boards for two more screws in each board to secure them to the center support. Use only one screw at the back edge of the front shelf board.

Step 5: Construct the peg rail (Figure 4).

a. Mark the center point of each end of a 1 x 6 x 54½-inch board (about 2¾ inches), and draw a horizontal line across the length of it using a straightedge. Then mark a line centered between the ends of the board. On each side of this centerline, mark lines at 6 inches, 12 inches, and 18 inches.

b. Using a ½-inch spade bit, drill a peg hole at each center point where a vertical line crosses the horizontal line.

c. Apply a small amount of wood glue around the end of each peg, and tap the pegs into the holes. Wipe off excess glue.

Step 6: Center and attach the peg rail flush with the top of back legs. Attach the 1 x 4 backsplash, flush and on top of the top shelf board, to the back legs using 2-inch screws.

Step 7: Construct and attach the pigeonhole assembly (see Figure 5).

a. Attach dividers to one of the three 1 x 6 x 54½-inch pigeonhole storage boards,

creating the back of the unit. Pre-drill with a ⅜-inch bit; use 2-inch screws and glue to attach the first two dividers on the ends, the third in the center of the board, and the last two 18 inches from the center divider.

b. Attach a second pigeonhole storage board as the top, resting at an angle atop the dividers. Caulk the back-edge gap.

c. Attach the third pigeonhole board to the top of the frame and peg rail by pre-drilling and using 2-inch screws and glue. Drill ⅜-inch holes in this board, as needed, to provide drainage. Attach the entire pigeonhole assembly from Steps 7a and 7b to the pigeonhole board in Step 7c by pre-drilling through the bottom board into the divider boards with a ⅜-inch bit, then securing with 2-inch screws and glue in each divider.

Step 8: Attach the lattice panels to the back of the bench (see Figure 6).

a. Using the remaining 1¼-inch screws, fasten the bottom panel into the back legs.

b. With ⅜-inch exterior screws, fasten the top panel into the back of the peg rail and the backsplash.

Step 9: Attach the top shelf edge bands.

a. Cut to fit the four top shelf edge band pieces, mitering corners. The two sides are approximately 24¾ inches from long point to long point; the front and back are approximately 59½ inches from long point to long point.

b. Attach using 4d finishing nails.

c. Finish the potting bench as desired. Secure the unit to the wall with L-brackets for added safety. ■

CUT LIST

Part Name	Material	Length	Quantity
front legs	2 x 2	35¼ inches	2
back legs	2 x 2	66 inches	2
top and bottom, side and center shelf supports	2 x 2	16 inches	6
top and bottom, front and back shelf supports	2 x 2	48 inches	4
bottom shelf boards	1 x 6 x 8	19 inches	9
top shelf boards	1 x 6 x 10	58¼ inches	4
board for pegs	1 x 6 x 10	54½ inches	1
pigeonhole storage boards cut from 1 x 6 x 10	1 x 6	54½ inches	3
pigeonhole dividers top edge slants downward from back to front	1 x 6 x 10	5½ inches (back); 4¼ inches (front)	5
backsplash	1 x 4	51 inches	1
lattice top panel	lattice	51 x 24 inches	1
lattice bottom panel lattice	51 x 24 inches	1	1
top-edge band (cut to fit ends after mitering)	1 x 2	about 24¾ inches	2
top-edge band (cut to fit front and back ends after mitering)	1 x 2	about 59½ inches	2

Figure 5

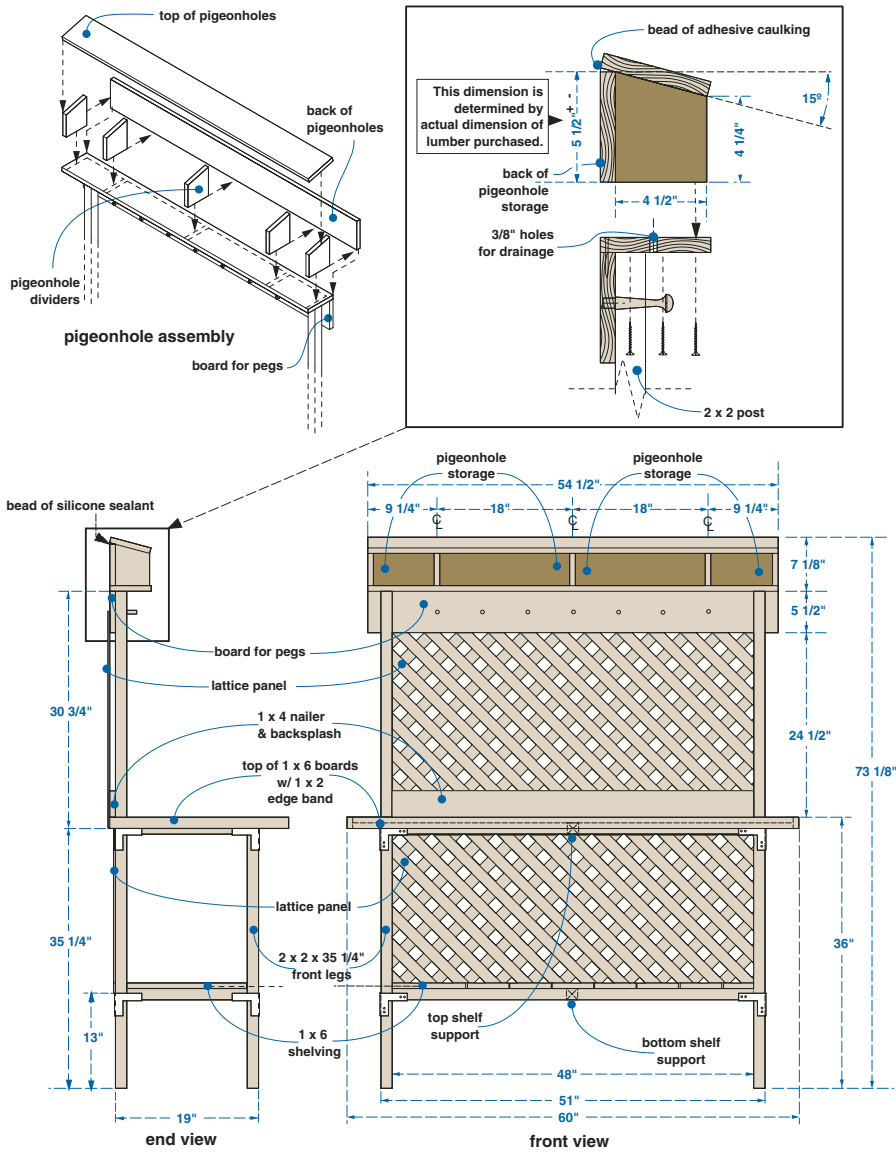
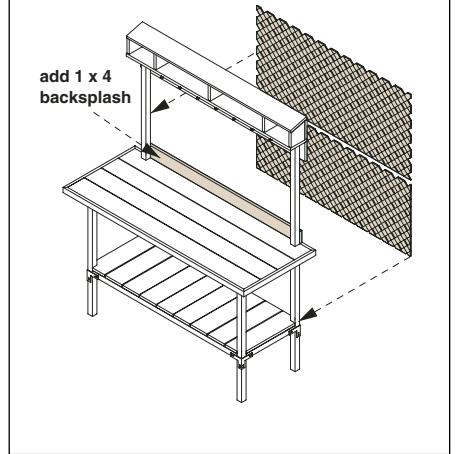
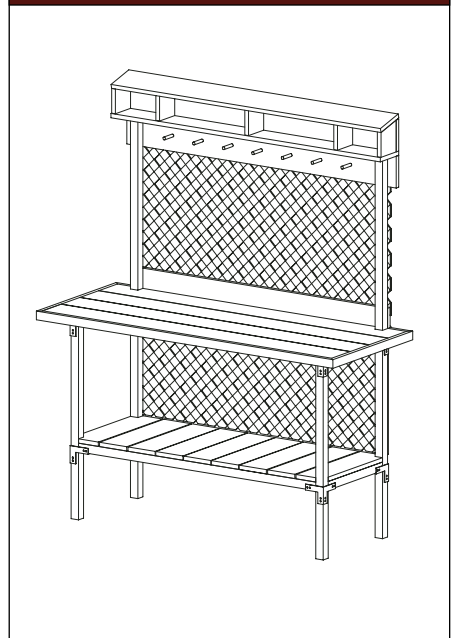

Figure 6



Assembly



TOOL LIST

- circular saw, miter or table saw
- saber saw
- framing square
- wood clamps
- drill with countersink bit, pilot bit, and screwdriver bit
- 1/2-inch spade bit
- nail gun or hammer

Finished Dimensions:

Height: 73 1/8 inches
 Depth: 20 1/2 inches
 Width: 60 inches

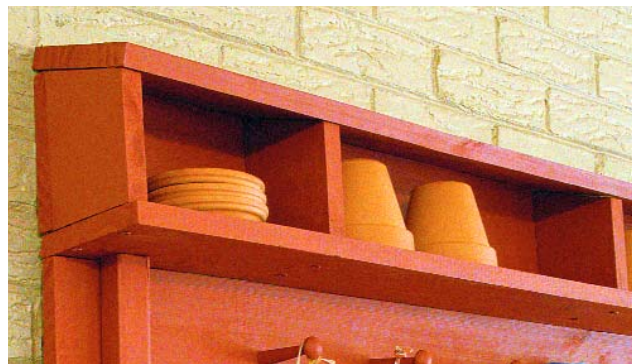

Compartments keep small items and tools close at hand. Attach furniture slides to the legs to minimize the absorption of moisture from the ground into the wood. This will extend the life of the potting bench and delay deterioration.