

# PSB2201NSS

## GE Profile Advantium® 240 Wall Oven

**Note:** Cabinets installed adjacent to wall ovens must have an adhesion spec of at least a 194°F temperature rating.

**Note:** 2" minimum between cutouts when installed above warming drawer or single wall oven.

### Installation Information:

Before installing, consult installation instructions packed with product for current dimensional data.

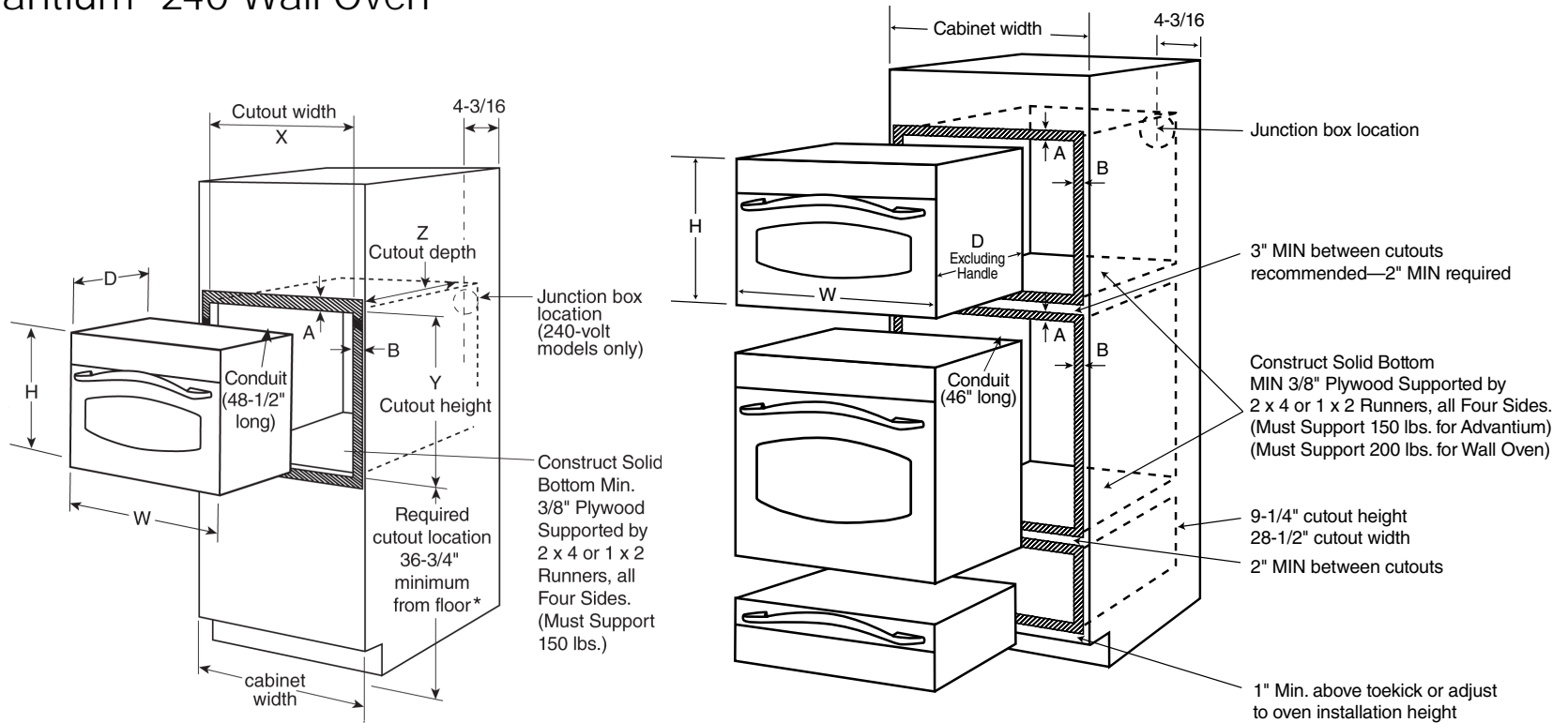

A=Allow 7/8" overlap of oven over bottom and 1/4" overlap at top edges of cutout.  
 B=Allow 2-1/8" for overlap of oven over side edges of cutout.

A=Allow 7/8" overlap of oven over bottom and 1/4" overlap at top edges of cutout.  
 B=Allow 2-1/8" for overlap of oven over side edges of cutout.

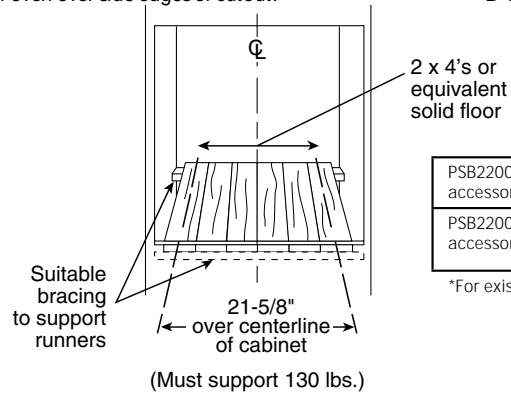

	Cabinet Width (inches)	W Width	H Height	D Depth (excluding handle)	X Cutout Width	Y Cutout Height	Z Cutout Depth (minimum)
PSB2200/1 without accessory drawer	30	29-25/32	19-1/8	21-1/2	25-1/8	17-1/2	23-1/2
PSB2200/1 with accessory drawer	30	29-25/32	22-1/4	21-3/4	25-1/8 to 28-1/2*	21	23-1/2

\*For existing cutouts a maximum width of 28-1/2" is acceptable

For answers to your Monogram®, GE Profile™ or GE® appliance questions, visit our website at [ge.com](http://ge.com) or call GE Answer Center® service, 800.626.2000.



imagination at work

